

### PUMP CHARACTERISTICS

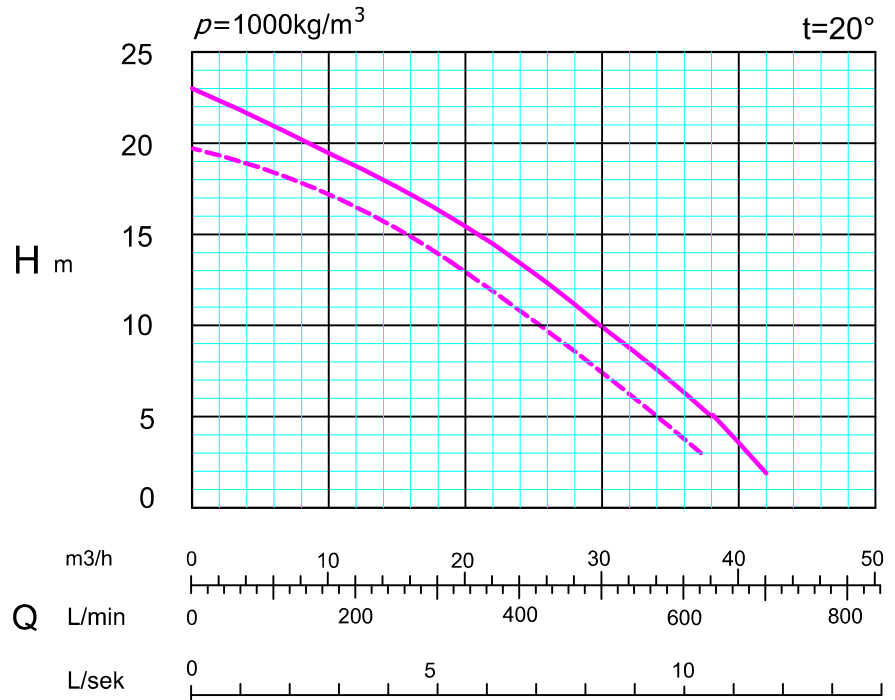
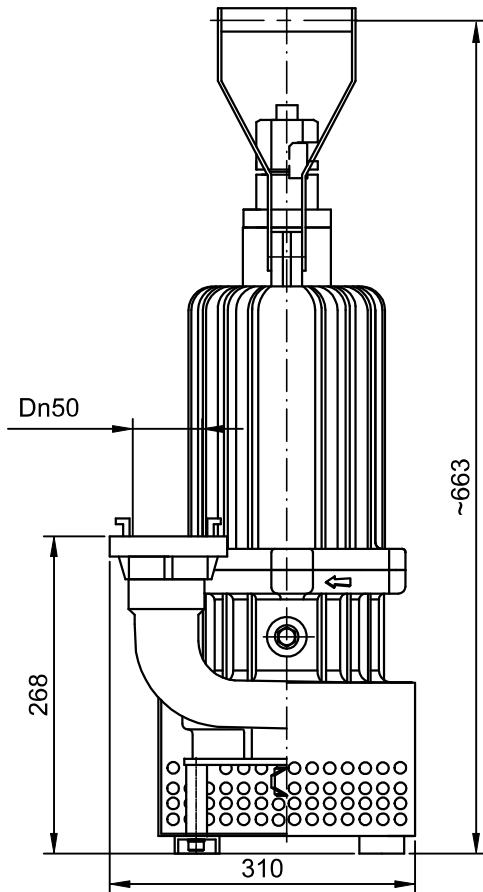

\* impeller construction:  
 — closed impeller (z)  
 - - - open impeller (o)

Pump is certified ATEX, number: OBAC 12 ATEX 247X

### PARAMETERS OF THE PUMP

		PZ-22GEz		PZ-22GEo	
Efficiency	[m <sup>3</sup> /h]	0-42		0-37	
Lift height	[m]	23-2		20-4	
Power (nominal)	[kW]	2,2		2,2	
Voltage	[V]	400	500	400	500
Nominal power consumption	[A]	4,7	3,7	4,7	3,7
Rotational speed	[rotation/min]	2855			
Weight	[kg]	41			
Maximal submergence level	[m]	8			
Protection degree		IP 68			
Explosion proof marking		IM2c		Ex dI Mb	
Max impurity	[mm]	18		15	