

PUMP CHARACTERISTICS

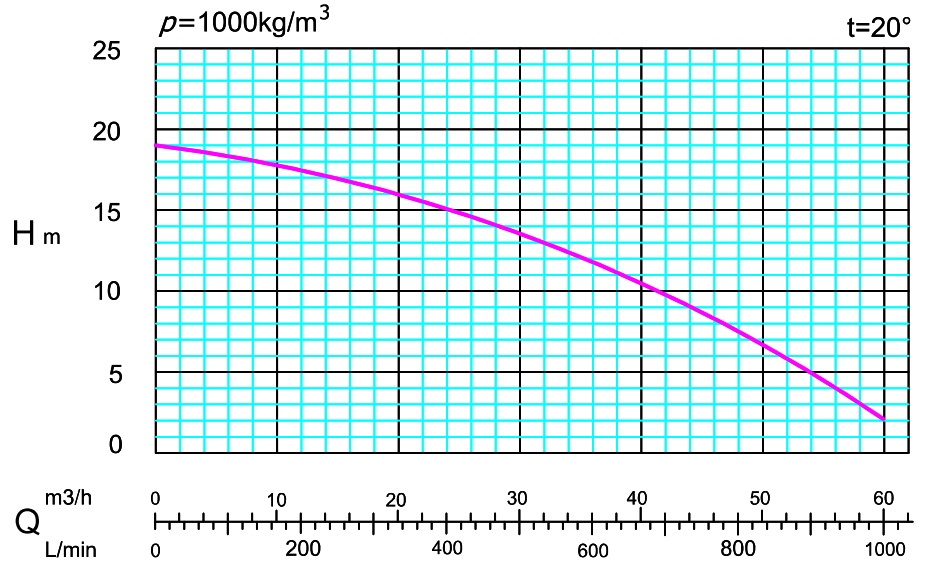
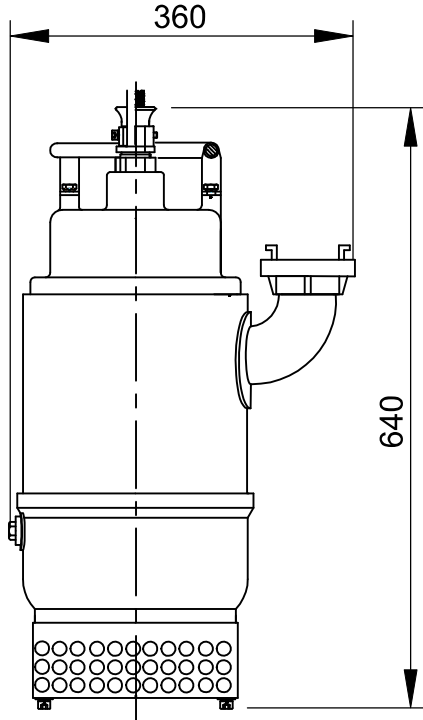

Pump is certified ATEX, number: OBAC 16 ATEX 0018X

PARAMETERS OF THE PUMP

Efficiency	[m ³ /h]	0-60	
Lift height	[m]	2-19	
Power	[kW]	2,2	
Voltage	[V]	500	1000
Nominal power consumption	[A]	3,7	1,9
Rotational speed	[obr./min]	2855	
Weight	[kg]	45	
Maximal submergence level	[m]	20	
Protection degree		IP 68	
Explosion proof marking		Ⓔ I M2 c Ⓔ I M2 Ex db I Mb	
Max impurity	[mm]	7	