

### PUMP CHARACTERISTICS

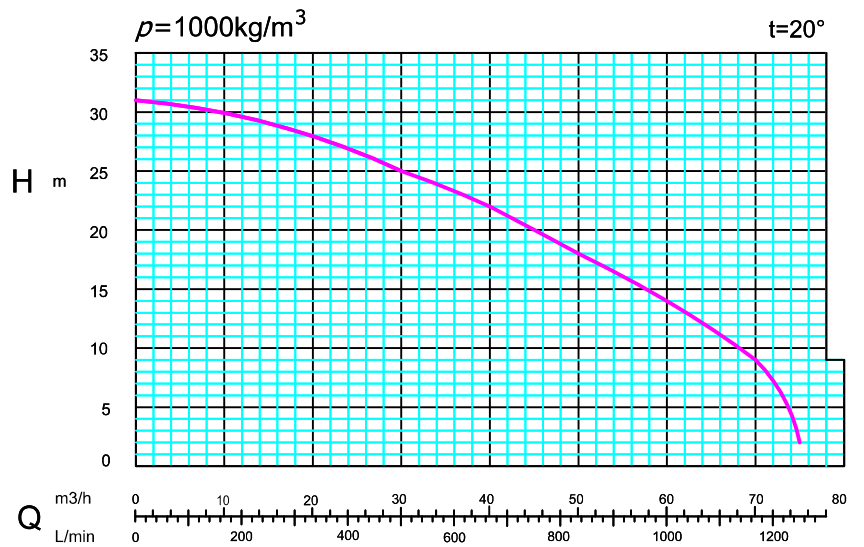
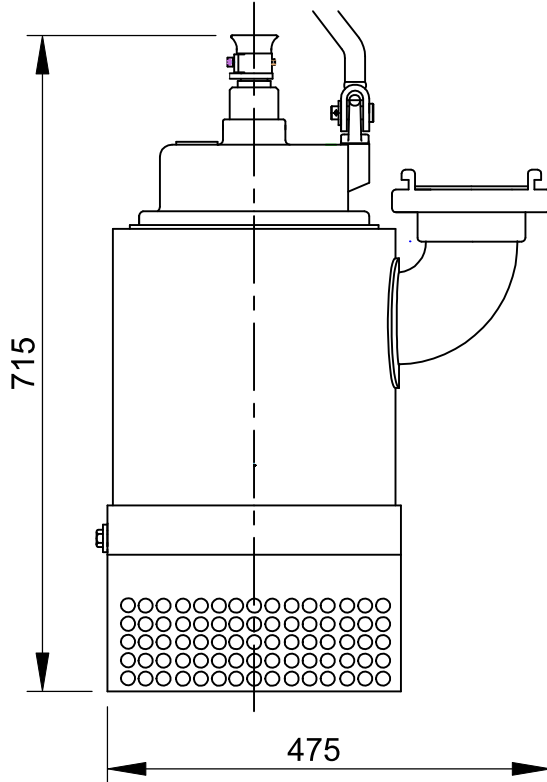

Pump is certified ATEX, number: OBAC 14 ATEX 0188X

### PARAMETERS OF THE PUMP

Efficiency	[m³/h]	0-75		
Lift height	[m]	31-2		
Power	[kW]	4,2		
Voltage	[V]	400	500	1000
Nominal power consumption	[A]	8,3	6,5	3,3
Rotational speed	[rotation/min]	2935		
Weight	[kg]	85		
Maximal submergence level	[m]	20		
Protection degree		IP 68		
Explosion proof marking		Ex I M2 c Ex I M2 Ex db I Mb		
Max impurity	[mm]	9		