

PUMP CHARACTERISTICS

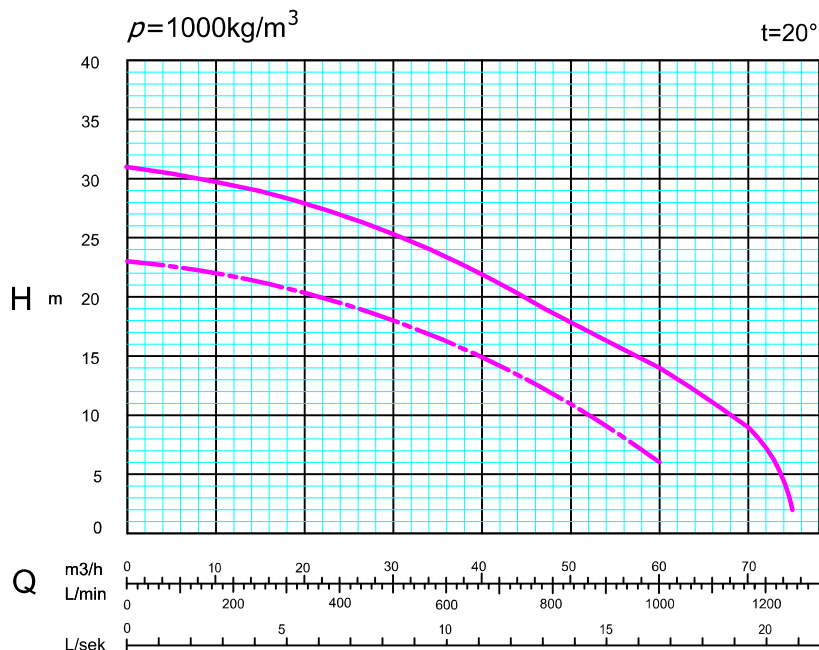
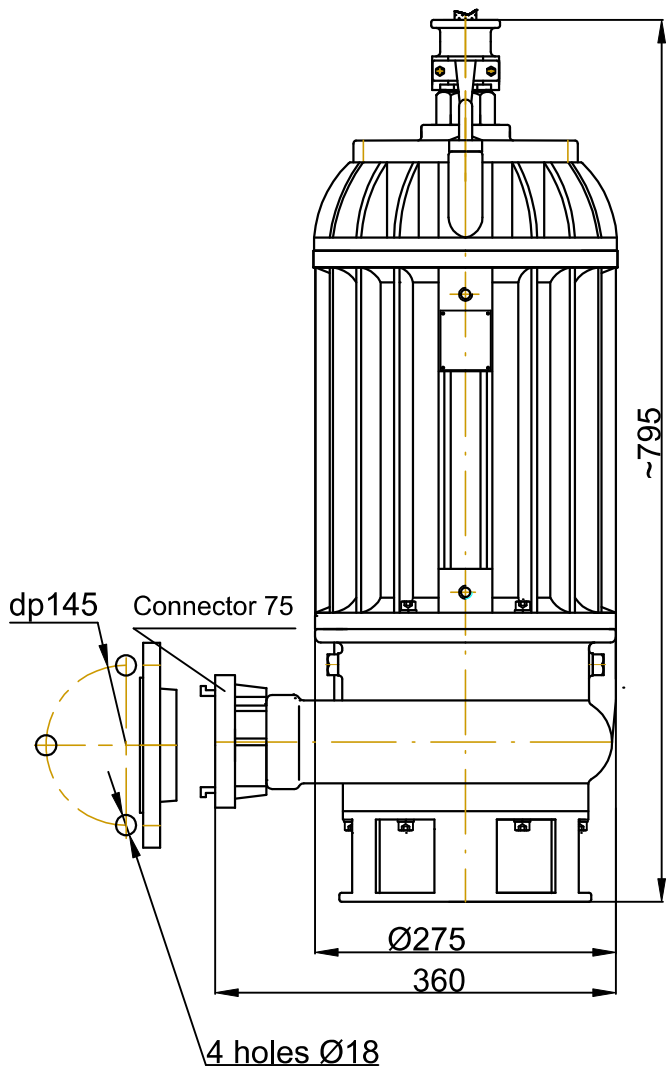

* impeller construction:
 — closed impeller (z)
 - - - open impeller (o)

* voltage version:
 1 - voltage 400V
 2 - voltage 500V
 3 - voltage 1000V
 4 - voltage 500/1000V
 switchable engine

Pump is certified ATEX, number: OBAC 11 ATEX 290X

PARAMETERS OF THE PUMP

		PSZ-65G*o			PSZ-65G*z		
Efficiency	[m3/h]	0-60			0-75		
Lift height	[m]	23-6			31-2		
Power	[kW]	5,0 - 7,0					
Voltage	[V]	400	500	1000	400	500	1000
Nominal power consumption	[A]	11,25	9	4	8	6,5	3,0
Rotational speed	[obr./min]	2920					
Weight	[kg]	100 - 124					
Maximal submergence level	[m]	20					
Protection degree		IP 68					
Explosion proof marking		IM2c Ex dI Mb					
Max impurity	[mm]	45			8		