

PUMP CHARACTERISTICS

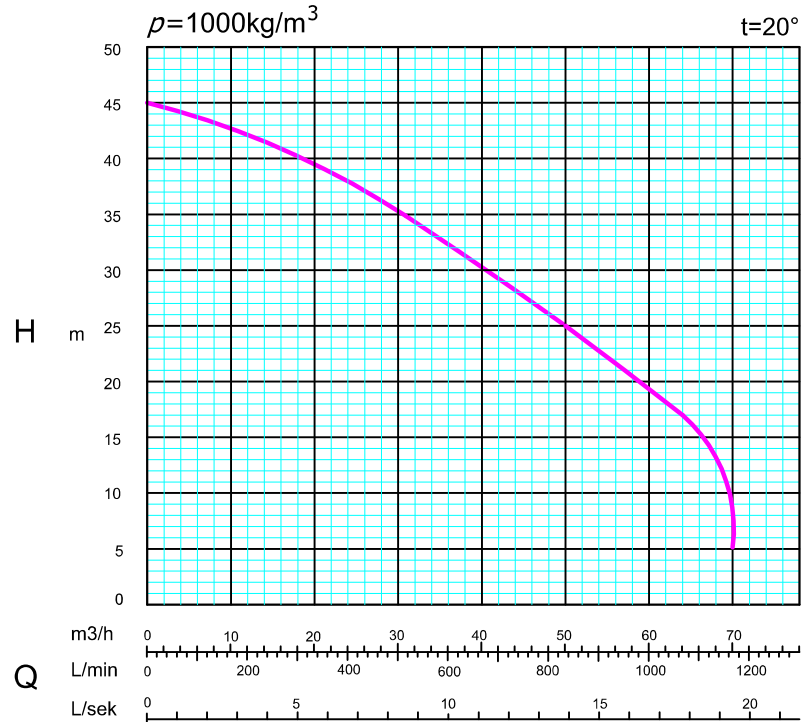
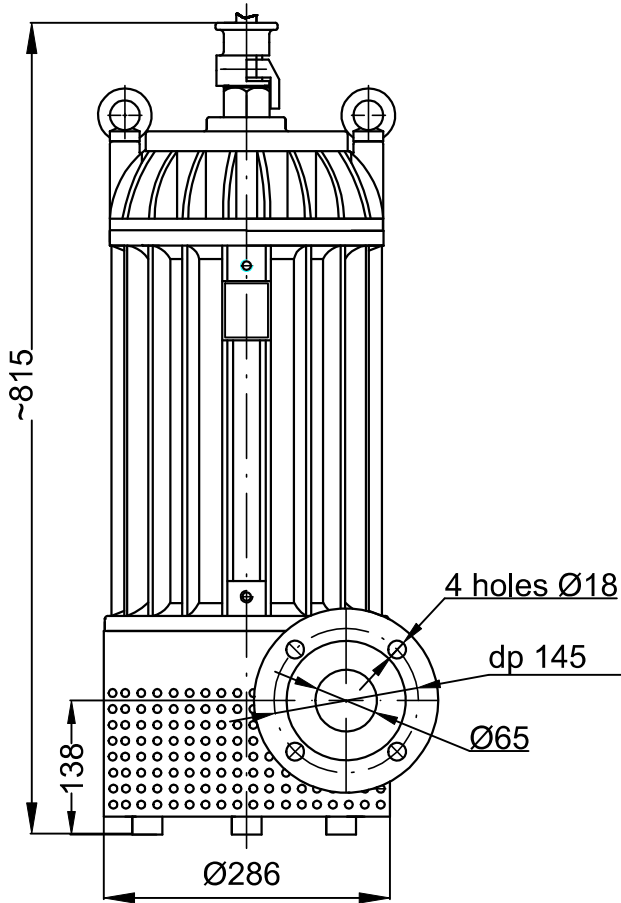

* impeller construction:
 — closed impeller (z)

* voltage version:
 1 - voltage 400V
 2 - voltage 500V
 3 - voltage 1000V
 4 - voltage 500/1000V
 switchable engine

Pump is certified ATEX, number: OBAC 11 ATEX 290X

PARAMETERS OF THE PUMP

Efficiency	[m ³ /h]	0-70		
Lift height	[m]	45-5		
Power (nominal)	[kW]	7,5		
Voltage	[V]	400	500	1000
Nominal power consumption	[A]	13,9	11,1	5,5
Rotational speed	[rotation/min]	2920		
Weight	[kg]	139		
Maximal submergence level	[m]	12		
Protection degree		IP 68		
Explosion proof marking		Ex IM2c Exd IMb		
Max impurity	[mm]	10		