

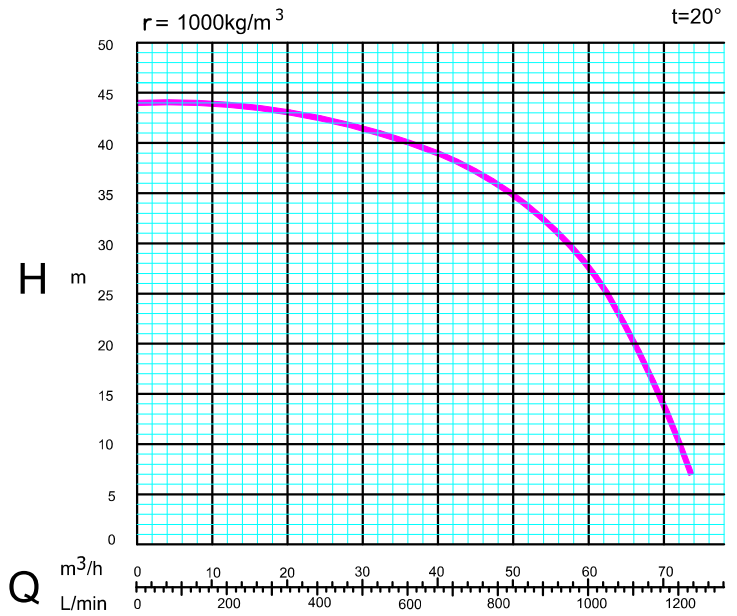

PUMP CHARACTERISTICS

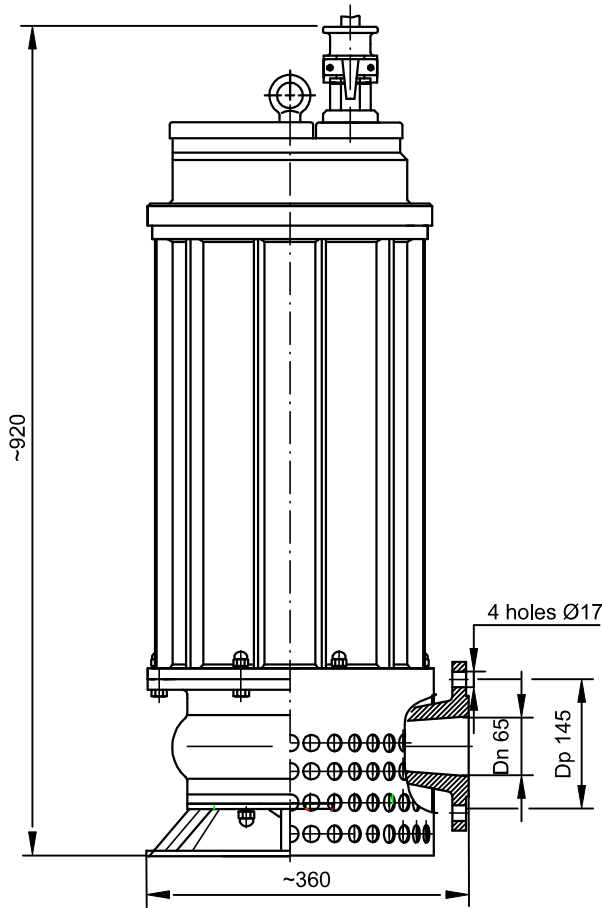

Pump is certified ATEX, number OBAC 09 ATEX 340X

PARAMETERS OF THE PUMP

Efficiency	[m3/h]	0-70	
Lift height	[m]	44-8	
Power (nominal)	[kW]	8	
Voltage	[V]	500	1000
Nominal power consumption	[A]	11	5,4
Rotational speed	[rotation/min]	2930	
Weight	[kg]	200	
Maximal submergence level	[m]	14	
Protection degree		IP 68	
Explosion proof marking		 IM2 Ex dl	
Max impurity	[mm]	17 or 28 (on stand)	