

### PUMP CHARACTERISTICS

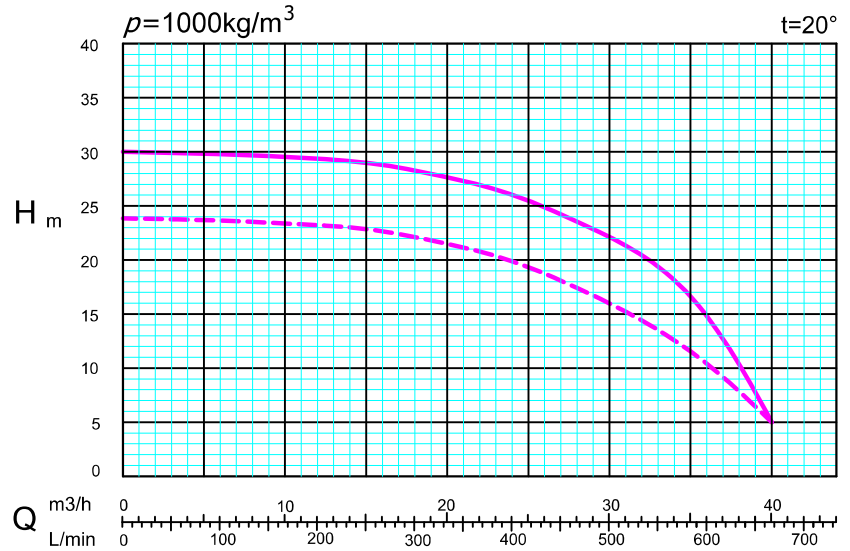
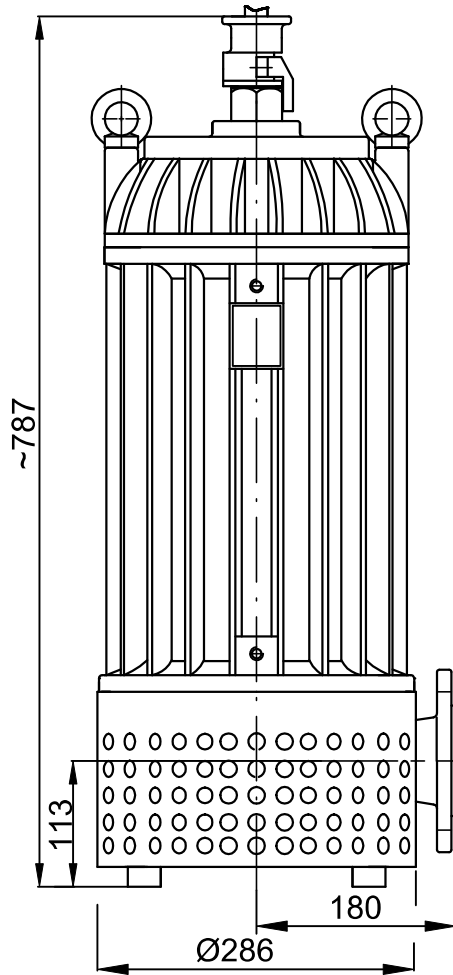

- \* impeller construction:
  - closed impeller (z)
  - - - open impeller (o)
- \* voltage version:
  - 1 - voltage 400V
  - 2 - voltage 500V
  - 3 - voltage 1000V
  - 4 - voltage 500/1000V switchable engine

Pump is certified ATEX, number: OBAC 11 ATEX 290X

### PARAMETERS OF THE PUMP

		PSZ-50C*z			PSZ-50C*o		
Efficiency	[m3/h]	0-40			0-40		
Lift height	[m]	30-5			24-5		
Power (nominal)	[kW]	4,5			4,5		
Voltage	[V]	400	500	1000	400	500	1000
Nominal power consumption	[A]	9,4	7,2	4,2	9,0	7	4,0
Rotational speed	[rotation/min]	2920					
Weight	[kg]	121					
Maximal submergence level	[m]	12					
Protection degree		IP 68					
Explosion proof marking		Ex IM2c Ex dI Mb					
Max impurity	[mm]	15			26		