

PUMP CHARACTERISTICS

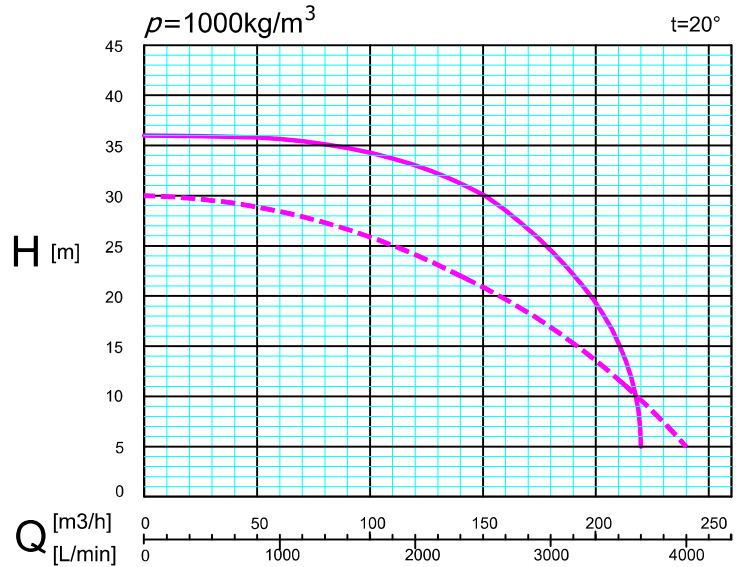
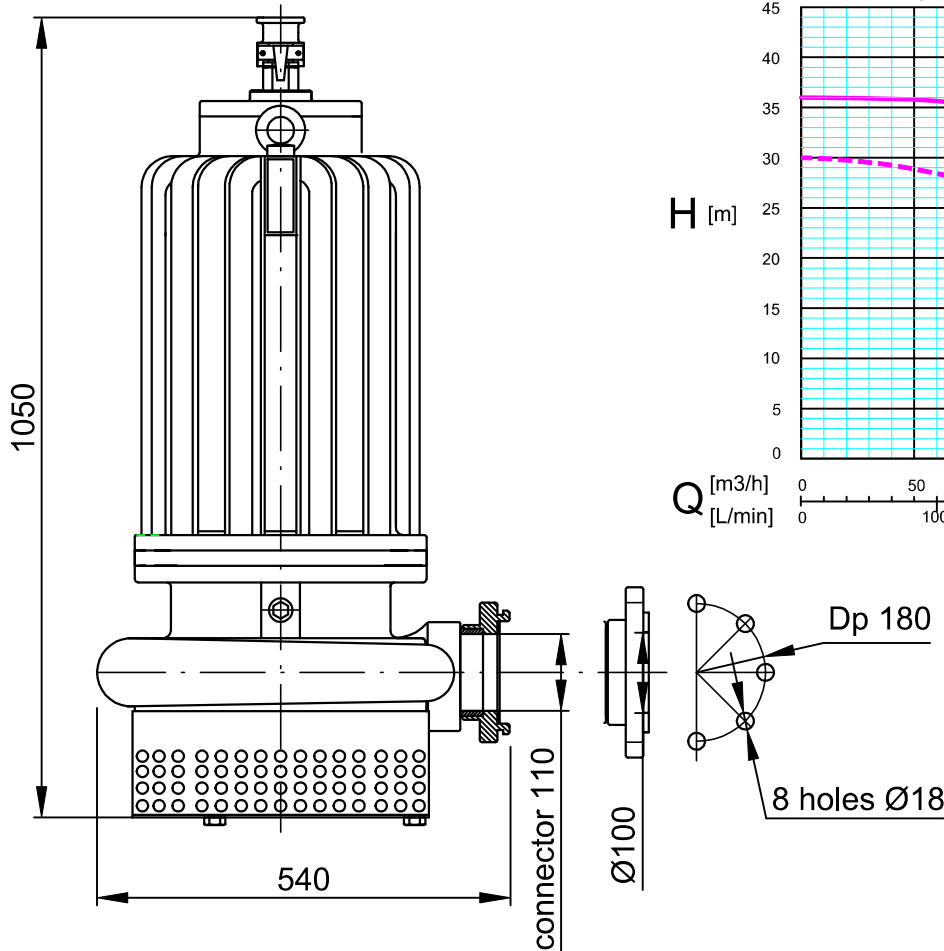

* impeller construction:
 — closed impeller (z)
 - - - open impeller (o)

* voltage version:
 A - voltage 500V
 B - voltage 1000V
 C - voltage 500/1000V
 switchable engine

Pump is certified ATEX, number: OBAC 11 ATEX 661X

PARAMETERS OF THE PUMP

		PSZ-100*z	PSZ-100*o
Efficiency	[m³/h]	0-220	0-240
Lift height	[m]	36-5	30-5
Power (nominal)	[kW]	22	
Voltage	[V]	500/1000	
Nominal power consumption	[A]	31,5/15,7	
Rotational speed	[rotation/min]	1463	
Weight	[kg]	325	
Maximal submergence level	[m]	8	
Protection degree		IP 68	
Explosion proof marking		Ex IM2c Ex dI	
Max impurity	[mm]	20	35