

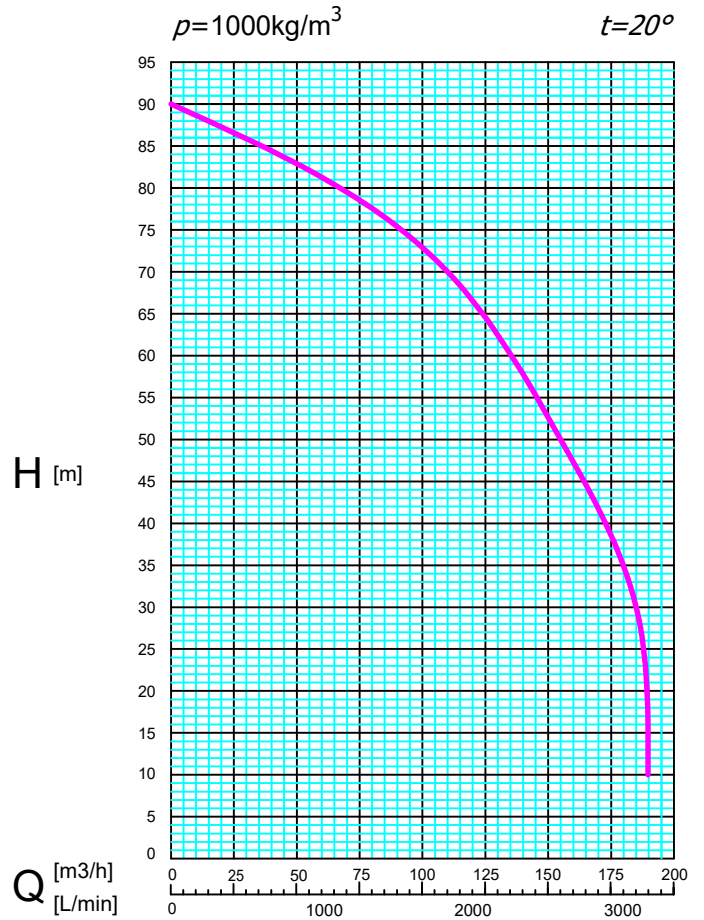

PUMP CHARACTERISTICS

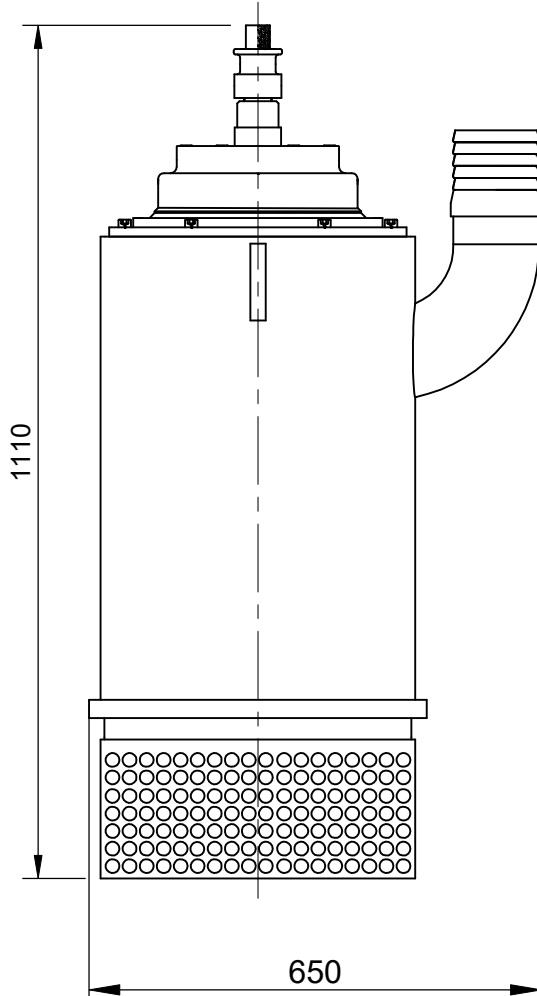

Pump is certified ATEX.

PARAMETERS OF THE PUMP

Efficiency	[m ³ /h]	0-190	
Lift height	[m]	90-10	
Power	[kW]	45	
Voltage	[V]	500	1000
Nominal power consumption	[A]	61	30
Rotational speed	[rotation/min]	2920	
Weight	[kg]	410	
Maximal submergence level	[m]	20	
Protection degree		IP 68	
Explosion proof marking		 I M2 Ex db I Mb	
Max impurity	[mm]	10	